

Isolation Hangers Type RSHWD

55mm Total Static Deflection, Spring & Rubber Element

APPLICATION

For support of pipework and equipment with speeds down to the order of 500 RPM requiring effective isolation of both mechanical vibration and acoustical level frequencies. Typically used for support of piping and ducts, low speed fans, packaged air conditioners, attenuators, etc.

FEATURES

- Heavy duty stable steel spring
- Rugged, heavy gauge steel cage
- Separate rubber acoustical isolating element
- Large diameter lower rod clearance hole in cage

OPTION

- Spring deflection scale and pointer plate
- Pre-compressed spring (suffix P in type code)
- Double deflection rubber element (RDSHWD)

DESIGN

RSHWD hangers incorporate a steel spring and a separate rubber acoustical isolating element mounted in a steel cage.

Springs used in RSHWD hangers are designed with a horizontal to vertical stiffness ratio of between 0.9 and 1.1 at rated load; ratio of spring diameter to loaded height minimum 0.8 and a rated maximum operating deflection of 2/3 deflection to solid.

ACOUSTICAL ISOLATION

Although steel spring mounts provide particularly effective isolation of mechanical vibration, the spring itself, depending on its physical geometry, may transmit certain audible level frequencies.

In RSHWD hangers, spring transmission of most audible frequencies is effectively minimised by the use of a separate rubber element mounted in the top of the hanger cage. These elements are selected for an average deflection of 5mm at rated load so that, for type RSHWD, the theoretical isolation of audible frequencies is generally better than 98%. For full dynamic performance of the element, refer to Datasheet RHE.

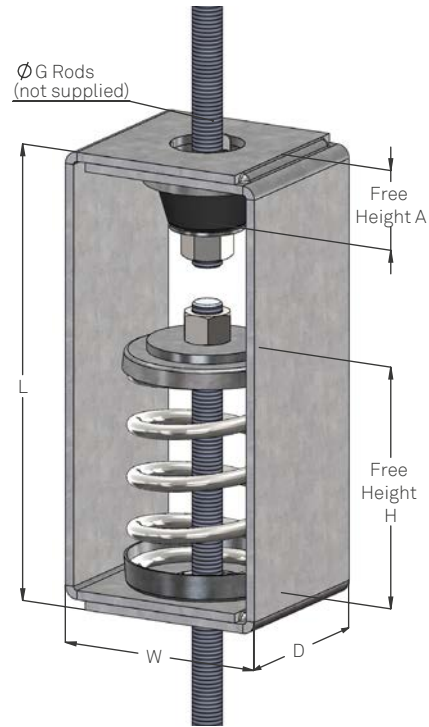

RSHWD

RSHWD PRODUCT GUIDE

Type	Max Load kg	Static Deflection mm	Spring Constant kg/mm	Spring Colours	
				Stripe 1	Stripe 2
RSHWD-33	50	55	1.0	White	-
RSHWD-34	75	55	1.5	Violet	-
RSHWD-35	110	55	2.2	Yellow	-
RSHWD-36	150	55	3.0	Brown	-
RSHWD-37	200	55	4.0	Orange	-
RSHWD-38	250	55	5.0	Orange	Black
RSHWD-39	350	45	8.8	Orange	Green

RSHWD Dimensions

Type	H mm	L mm	W mm	D mm	A mm	ØG (max) mm
RSHWD - SINGLE DEFLECTION						
33-37	145	250	115	100	43	M16
38	155	250	115	100	43	M16
39	155	250	115	100	58	M20
RDSHWD - DOUBLE DEFLECTION						
33-37	145	250	115	100	56	M16
38	155	250	115	100	56	M16
39	155	250	115	100	85	M20

MISALIGNMENT CAPABILITY

The lower rod hole in the cage is a minimum of 50% larger in diameter than the maximum rod size to allow for installation misalignment. When installed correctly and under load, the RSH hanger automatically self-aligns by pivoting on the rubber element. In this way misalignment can be accommodated without interference between hanger rods and cage.

PRE-COMPRESSION (suffix P in type code)

To aid installation of complex equipment and piping systems, the hanger maybe supplied complete with lower rod and with the spring pre-compressed under load (the standard pre-compression setting is 75% of rated load). In this way the hanger can act as a rigid connection to facilitate leveling of the system. When full operating loads are applied (e.g. when pipes are filled) the hanger load is transferred to the spring so that the hanger acts as an isolator and normal adjustment of levels is then all that is necessary.

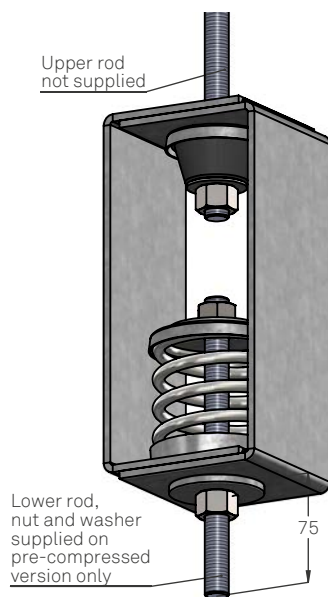

RSHWD PRE-COMPRESSION

DEFLECTION SCALES

Pointer plates and deflection scales, indicating spring deflection only, can be fitted as an optional extra.

HANGER SELECTION

When selecting hangers, it is recommended that a safety factor of 10-20% is applied to the calculated mass of equipment to avoid overloading of any hanger. If maximum rated deflections are required, then equipment should be weighed and an accurate assessment of point loads made.

INSTALLATION

1. Piping or equipment should be hung at its proper elevation by using temporary fixtures that can be removed after hangers are installed and adjusted.
2. For best results, hangers should be at or near the ceiling. When used for pipe support with little or no longitudinal expansion, cages maybe hard bolted to the support point.
3. Ensure the structural support point is vertically above the centre of the pipe or equipment support point.
4. To load the spring, turn the upper nut on the lower rod clockwise.

TECHNICAL ASSISTANCE

All Embelton offices can provide detailed technical assistance on the use of this product in specific applications.

CONDITIONS OF SALE

These products are sold subject to the published Embelton General Conditions of Sale, copies of which maybe inspected on request.

SPECIFICATION

Resilient piping or equipment supports shall incorporate a stable steel spring capable of up to 50mm rated static deflection, housed in a heavy duty steel cage. Springs shall have a minimum additional travel of 50% rated deflection to solid. Acoustical isolation must be achieved by use of a separate resilient rubber element of deflection 5mm incorporated into the steel hanger. They shall be type RSHWD as supplied by Embelton.